

» **Features**

- Sharp "click" feeling with positive reliability feedback.
- Precise design terminal type adequate for DIP IC pitch size (multiple of 2.54mm).
- Several LED colors options.
- Adequate for DIP & SMT.
- Several cap legends options.

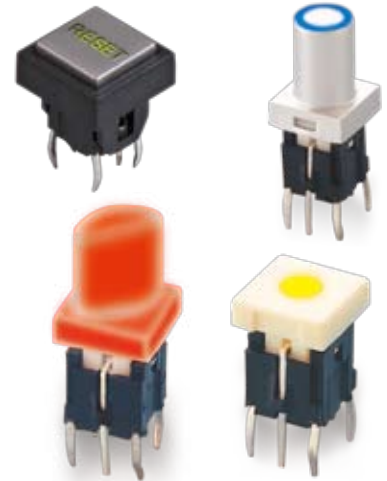

» **Applications**

- Operating switches in all types of electronic equipment such as audio apparatus, office equipment, communications apparatus, TV sets, VCRs, etc.

» **Specifications**

Rating	50mA 12VDC
Insulation Resistance	100MΩ Min (at 500 VDC)
Dielectric Strength	AC 250V (50/60 Hz for 1 minute)
Contact Resistance	100mΩ Max. (Initial)
Electrically Life	300,000 Cycles Min
Ambient Temperature	-20°C~ +70°C
Operating Force	160 ± 50gf
Travel	0.25 ± 0.1 mm

» **LED Specifications**

Color	VR	IF	Recommended Operating Current	VF	
				Nor	Max
Red	DC 5V	20mA	20mA	1.7V	2.4V
Green	DC 5V	20mA	20mA	1.9V	2.4V
Yellow	DC 5V	20mA	20mA	1.9V	2.4V
Blue	DC 5V	20mA	20mA	3.0V	3.6V
White	DC 5V	20mA	20mA	3.0V	3.6V

For the specification about the other LEDs, please contact with sales department

» **Product selection**

PB 614

BUTTON TYPE		FUNCTION		LED COLOR		LASER ETCHING COLOR		LASER ETCHING	
1F		Non-LED		1		1	Misty Silver	01	
2F		Standard type		2		2	Bright Silver	02	
3F		M	SMT type	3		3	Gold	03	
1		LED		4		4	White	04	
4		L	Standard type	5		5	Bright Black	05	
5		ML	SMT type	6		6	Red	06	
6		FRAME		8		7	Misty Black	07	
8		-	Without	9		8	Sky blue	08	
9		F	With frame	10		9	Gunmetal Black	09	
10				011		A	Orange	10	
11				12					
12				13					
13				14					
				23					
				48					
				52					
				58					
				-	Non-LED				

Please inquire about the details with our sales representative.

» Operating characteristics

Unit: mm

Dimensions

P.C.B Layout

PB6141FL

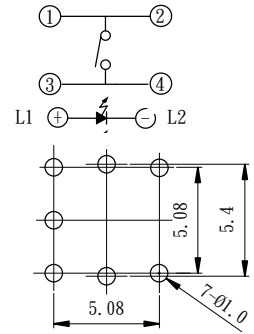
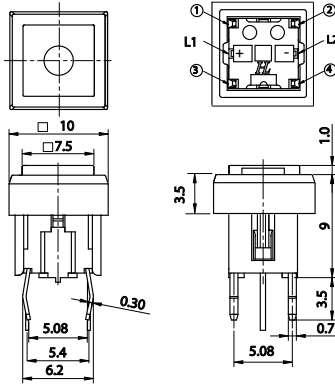

PB6142FL

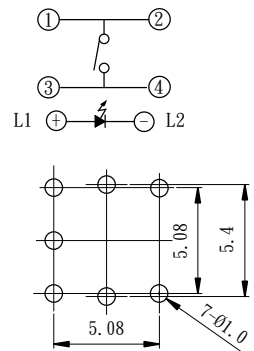
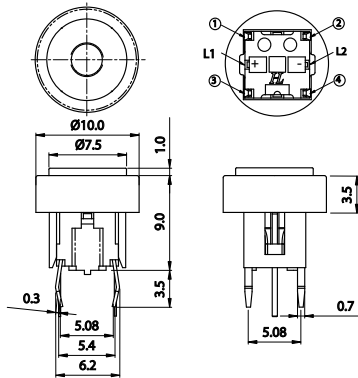

PB6143FL

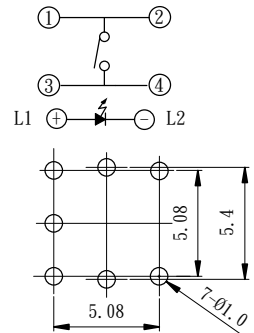
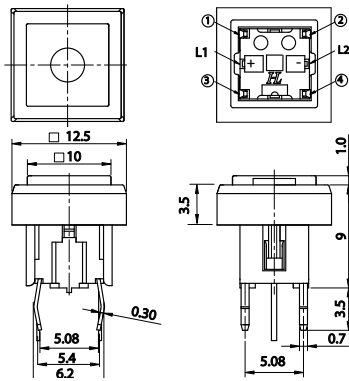

PB6141L

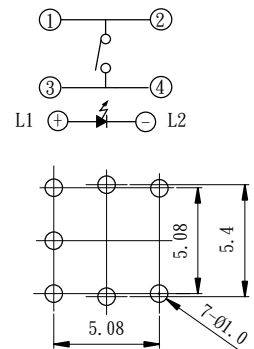
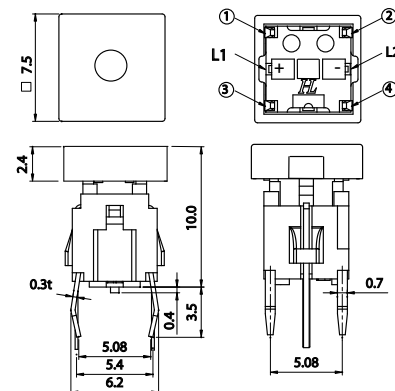

PB 614 SERIES TACT SWITCHES

ILLUMINATED

» Operating characteristics

Unit: mm

Dimensions

P.C.B Layout

PB6144L

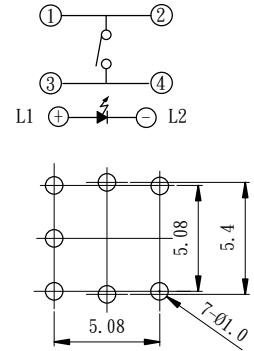
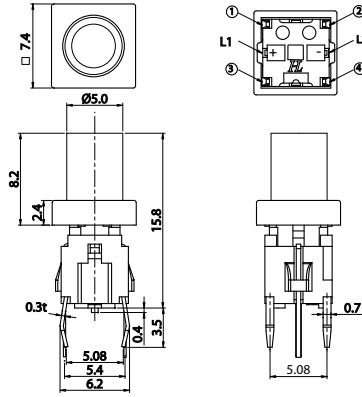

PB6145L

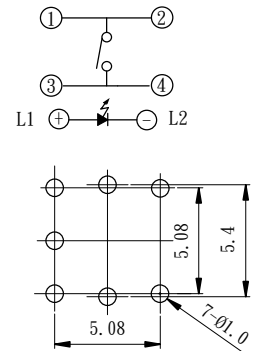
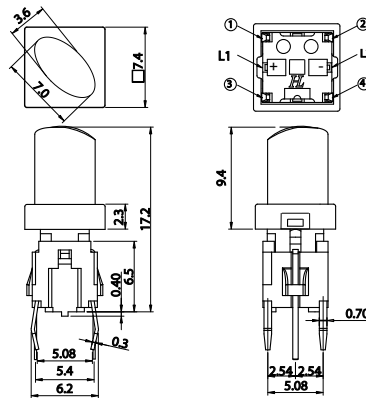

PB6146L

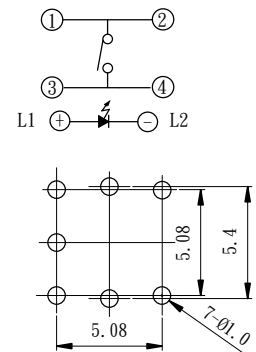
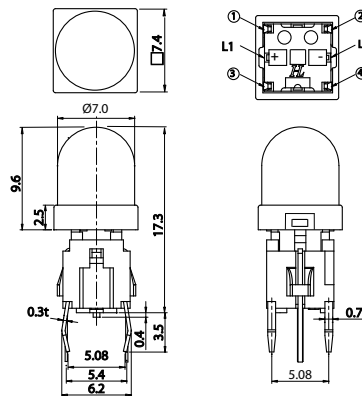

PB6149L- \square -102

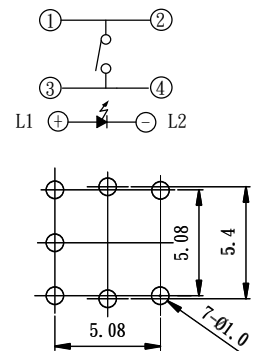
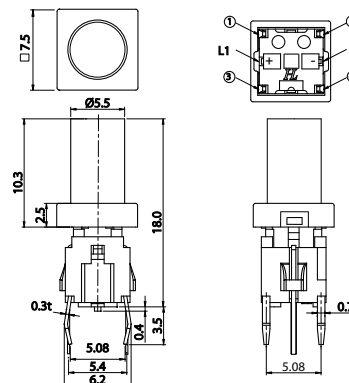

» Operating characteristics

Unit: mm

Dimensions

P.C.B Layout

PB61410L

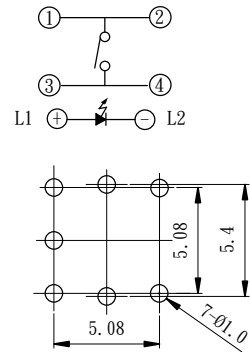
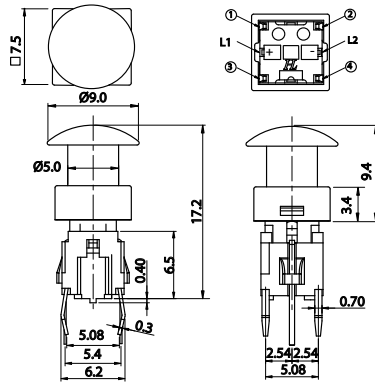

PB61411L-□-103

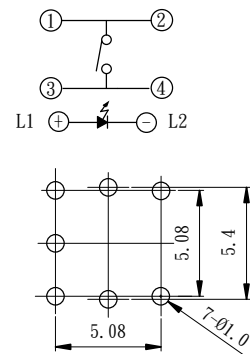
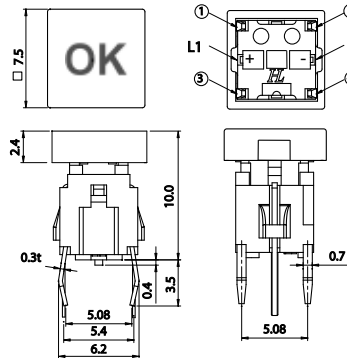

PB61412L-□-104

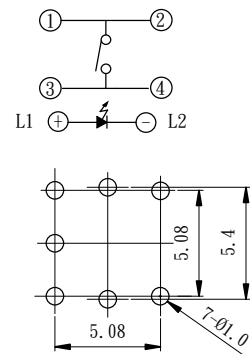
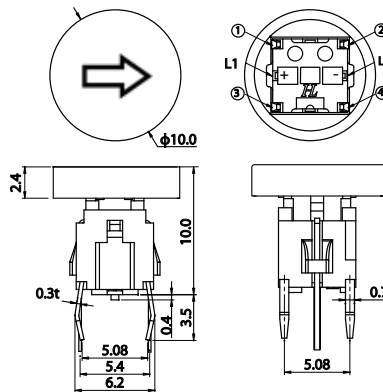

PB61413L-□-101

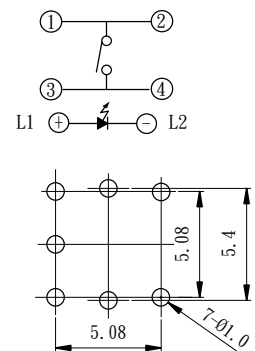
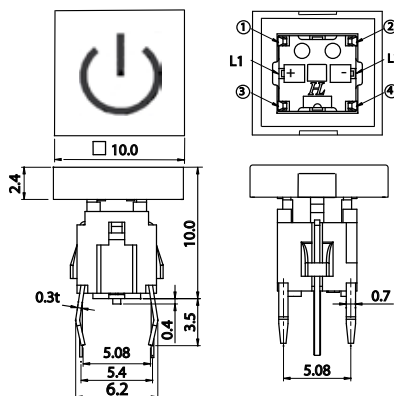

PB 614 SERIES TACT SWITCHES

ILLUMINATED

» Operating characteristics

Unit: mm

Dimensions

P.C.B Layout

PB61415FL-□-102

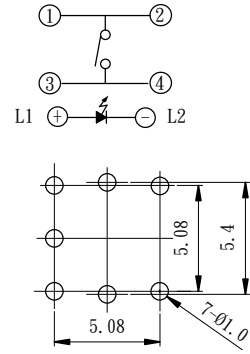
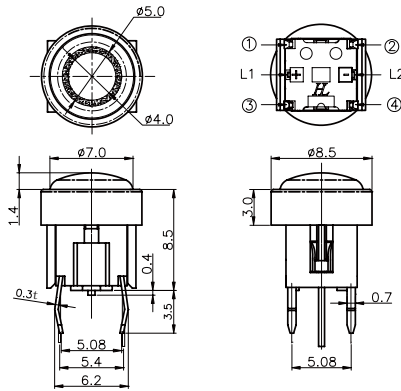

PB61416FL-□-5307

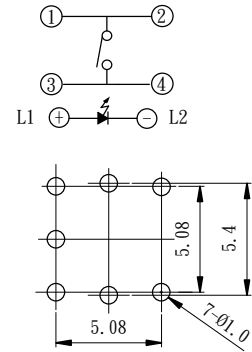
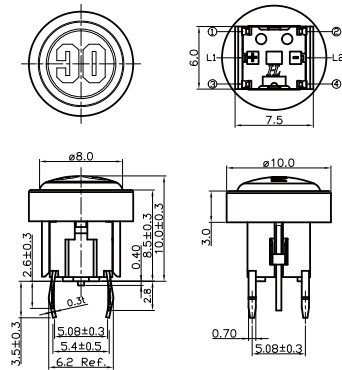

PB61417FL-□-6102

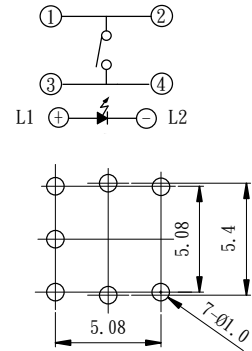
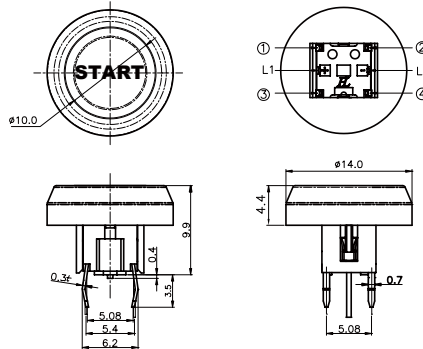

PB61422FL-□-850R

